

morphy richards®

smart ideas for your home

Compact Ice Maker

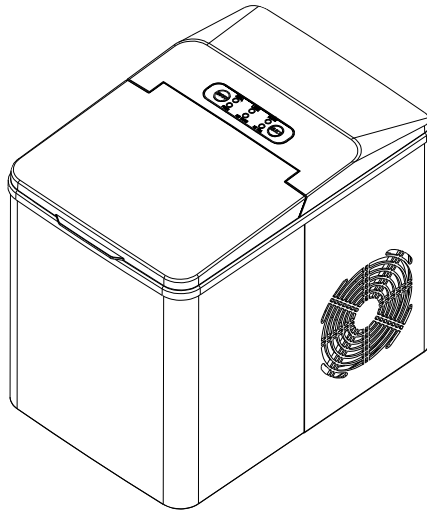

Model: MRICE12SS

INSTRUCTION MANUAL

Read these instructions carefully before
using this appliance for the first time.

STORE THESE INSTRUCTIONS CAREFULLY

For product hints and tips plus more join us at

www.morphyrichards.com.au



facebook.com/MorphyRichardsAUS



instagram.com/morphyrichardsau

IMPORTANT SAFETY INSTRUCTIONS

READ CAREFULLY AND KEEP FOR FUTURE REFERENCE

To reduce the risk of fire, electric shock, injury to persons or damage to property, follow basic precautions including the following:

- **WARNING:** Misuse of appliance could cause personal injury.
- Check your ice maker to ensure it is in good condition and that there is no damage to the ice maker, power cord and plug.
- This appliance is not intended for use by persons (including children) with reduced physical, sensory or mental capabilities, or lack of experience and knowledge, unless they have been given supervision or instruction concerning use of the appliance by a person responsible for their safety. Children should be supervised to ensure that they do not play with the appliance.
- This appliance can be used by children aged from 8 years and above and persons with reduced physical, sensory or mental capabilities or lack of experience and knowledge if they have been given supervision or instruction concerning use of the appliance in a safe way and understand the hazards involved. Children shall not play with the appliance. Cleaning and user maintenance shall not be made by children without supervision.
- This appliance is intended to be used in household and similar applications such as

–staff kitchen areas in shops, offices and other working environments;

–farm houses and by clients in hotels, motels and other residential type environments;

–bed and breakfast type environments;

- **WARNING:** Do not store explosive substances such as aerosol cans with a flammable propellant in this appliance.
- **WARNING:** Keep ventilation openings, in the appliance enclosure or in the built-in structure, clear of obstruction.
- **WARNING:** Do not use mechanical devices or other means to accelerate the defrosting process, other than those recommended by the manufacturer.
- **WARNING:** Do not damage the refrigerant circuit.
- **WARNING:** Do not pour coloured drinks or congee drinks into the machine (including the water tank and ice tray).
- **WARNING:** Do not use electrical appliances inside the food storage compartments of the appliance, unless they are of the type recommended by the manufacturer.
- **WARNING:** Do not locate multiple portable socket-outlets or portable power supplies at the rear of the appliance.
- **WARNING:** When disposing of the appliance, do so only at an authorized waste disposal centre. Do not expose to flame.
- **WARNING:** This appliance contains a small quantity of R600a refrigerant which is flammable.
- **WARNING:** It is hazardous for anyone other than an Authorised Service Person to service this appliance. In Queensland - the authorised Service Person **MUST** hold a Gas Work Authorisation for hydrocarbon refrigerants to carry out servicing or repairs where the gas system is being opened or charged.



WARNING: The refrigerant isobutene (R600a) is contained within the refrigerant circuit of the appliance, a natural gas with a high level of environmental compatibility, which is nevertheless flammable. During transportation and installation of the appliance, ensure that none of the components of the refrigerant circuit becomes damaged.

If the refrigerant circuit should be damaged:

- Avoid opening flames and sources of ignition.
- Thoroughly ventilate the room in which the appliance is situated.

Location

- Before using the Ice Maker for the first time, please wait 2 hours after positioning it, and keep the transparent lid open for at least 2 hours.
- For indoor use only. Do not use outdoors or near water.
- Always locate your appliance away from the edge of the worktop.
- Do not upend this product or incline it over a 45° angle. Ensure that the appliance is used on a firm, flat surface.
- Keep the appliance 15cm from other objects to ensure the heat generated is heat released.
- Do not use the appliance close to flames, hot plates or stoves.

Power cord

- **WARNING:** This appliance should NOT be used with extension leads and/or power boards.
- **WARNING:** When positioning the appliance, ensure the supply cord is not trapped or damaged.
- The power cord should reach from the socket to the appliance without straining the connections.
- If the power cord is damaged, it must be replaced by the manufacturer, its service agent or similarly qualified persons in order to avoid a hazard.

- Remove the plug from the socket, grasp the plug and pull out the power cord, do not pull on the cord directly.
- Do not let the cord hang over the edge of a table or counter and keep it away from any hot surfaces.
- Do not let the cord run across an open space e.g. between a low socket and table.

Personal safety

- **WARNING:** To protect against fire, electric shock and personal injury do not immerse cord, plug and appliance in water or any other liquid.
- **WARNING:** The appliance surface is subject to residual heat after use.
- **WARNING:** Fill with potable water only.
- The temperature of accessible surfaces may be high when the appliance is operating.
- Unplug from the outlet before cleaning and allow to cool before putting on or taking off parts and before cleaning.
- Do not move the appliance while switched on.
- Do not use accessories which are not recommended by the manufacturer.
- Do not touch the evaporator when using the ice maker as the user may suffer from frostbite.

Electrical requirements

- **WARNING:** This appliance should NOT be used with extension leads and/or power boards.
- Check that the voltage on the rating label of your appliance corresponds with your house electricity supply which must be A.C.

SPECIFICATIONS

Model:	MRICE12SS
Colour:	Stainless Steel / Black
Rated Power:	150W
Rated Voltage & Frequency:	220-240V~ 50Hz
Water Tank Capacity:	1.8L
Ice Bin Capacity:	0.8 kg
Refrigerant/Refrigerant Amount:	R600a/24g
Foaming Agent:	EPS
Dimensions (W x D x H):	228 x 336 x 292mm
Net Weight:	7.7kg

PRODUCT OVERVIEW

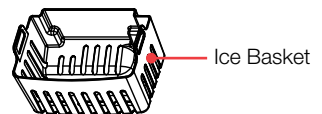
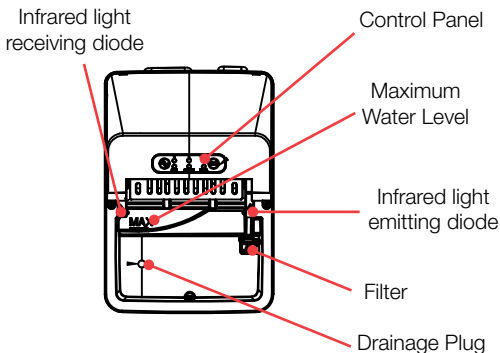
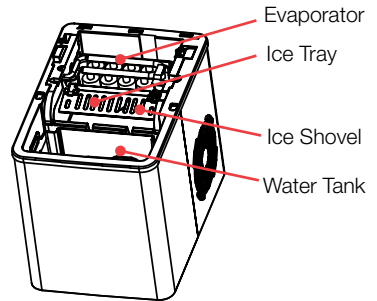
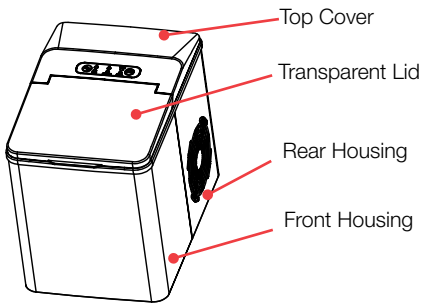

CONTROL PANEL

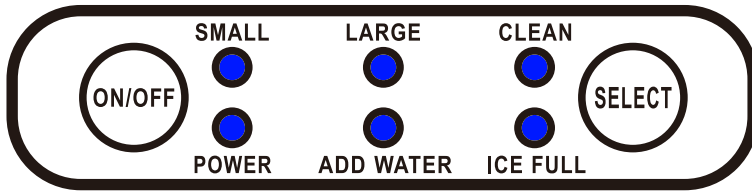

ON/OFF Button - Starts or Stops the appliance.

POWER Indicator - In standby mode the POWER indicator will blink. During operation the POWER indicator will be solid.

ICE FULL Indicator - When the ice reaches the maximum amount of ice in the ice tray, the ICE FULL indicator will illuminate.

ADD WATER Indicator - When the ADD WATER indicator illuminates, there is a water shortage in the water tank. You need to add water and press the ON/OFF button to restart the machine.

SMALL Ice Selection Indicator - When selecting small ice, the SMALL indicator will illuminate.

LARGE Ice Selection Indicator - When large ice is selected, the LARGE indicator will illuminate. Large ice is the default setting.

CLEAN Indicator - To run the CLEAN program, press the SELECT button to select the CLEAN during the standby mode.

SELECT Button - Whilst in the standby mode, press the SELECT button to select SMALL ice, LARGE ice or CLEAN. After selecting the desired function, press ON/OFF button to activate.

BEFORE FIRST USE

1. Remove all packaging materials and read all instructions.
2. Check that all accessories are complete and the appliance is not damaged.
3. Clean all parts to remove any dust or manufacturing residue.
4. Clean the water storage tank and ice collecting tray with clean water.
5. The incline angle of the ice maker should not exceed 45° during transportation or use. Do not turn the ice maker upside down. Doing so could cause the compressor or refrigerating system to operate incorrectly. Please allow time for the liquid in the compressor to settle after the ice maker is moved or transported. Before using the ice maker for the first time, please wait for 2 hours after the unit has been positioned on a level surface.
6. The appliance must be placed on a dry and level surface with sufficient ventilation, far from heat sources such as ovens, heaters and corrosive gases. Leave around 15cm clearance on all sides of the ice maker for proper ventilation.
7. Do not fill the water reservoir with hot water. This may damage the ice maker. It is best to fill the water tank with water that is room temperature or lower. The water quality added to the tank should be drinkable.
8. Do not use the appliance at a very cold environment (lower than 5°C).
9. Run the Clean Function, as described on page 7.

USING YOUR ICE MAKER

1. Ensure the drainage plug at the bottom of the water tank is closed securely.
2. Plug the ice maker into a wall outlet, the POWER indicator will blink.

NOTE: The appliance should be rested for 30 minutes before plugging into a wall outlet, if it has been moved.

3. Open the transparent lid, remove the ice basket and fill the water tank with drinkable water.

NOTE: Do not fill above the MAX water level mark.

4. Replace the ice basket and close the transparent lid.
5. If you want to clean the appliance, press the SELECT button and select CLEAN during the standby mode, then press the ON/OFF button to start cleaning.
6. The ice making cycle will last approximately 7-15 minutes, depending on the ambient temperature and water temperature.
7. The ice making cycle begins with water being pumped into the ice tray situated below the evaporator. Over the next 7-15 minutes ice forms on the evaporator. Once this has completed, the ice tray will tilt backwards and the remaining water in the ice tray is drained back into the water tank. Ice cubes are then dropped from the evaporator and pushed forward into the ice basket by the ice shovel. The ice tray will automatically move back into position under the evaporator and start the next cycle.
8. The ICE FULL indicator will illuminate when the ice basket is full and the ice maker will stop making ice automatically. Gently remove the ice from the ice basket with the ice scoop. About 5 seconds later, the ice maker will restart its ice making function automatically.

USING YOUR ICE MAKER

9. The ADD WATER indicator will light up when the water tank is out of water and the ice making cycle will stop automatically. Remove the ice basket and add water to the water tank, and then press the ON/OFF button again to restart the ice making cycle. The appliance will start working automatically after 20 minutes if the user forgets to restart the appliance after refill.
10. When you have the desired amount of ice, stop the ice making cycle by pressing the ON/OFF button and unplug the unit from the wall outlet.
11. Open the transparent lid and transfer the ice to a freezer.
12. Allow the ice maker to reach room temperature.

CARE & CLEANING

- Clean the water tank if the appliance has water in the tank and has not been used for 48 hours.
- If the appliance is left empty for long periods, switch off, defrost, clean, dry, and leave the lid open to prevent mould developing within the appliance.
- Tilt the appliance around 30° and move it forward to the place where the drainage plug is about 60mm away from the countertop. Open the drainage plug and drain the excess water (see below).

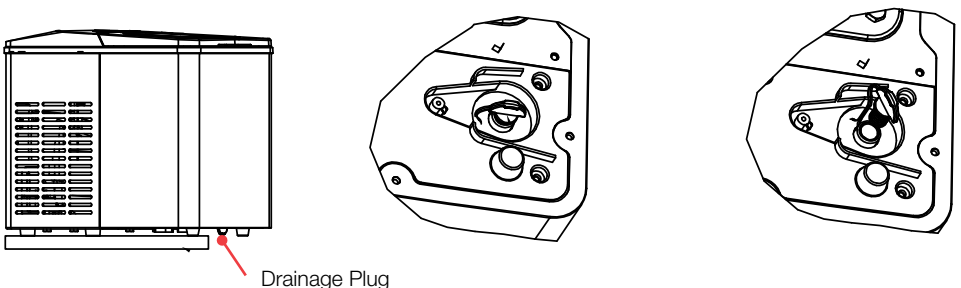

CARE & CLEANING

- Remove the ice basket and clean the ice maker interior with a soft cloth soaked with warm water and vinegar, then rinse with clean water and drain all the water.
- Replace the drainage plug securely in position. Wash the ice basket and ice scoop in warm soapy water. Rinse and dry.
- Clean the exterior of the ice maker with a soft damp cloth. Use a mild dishwashing soap, if necessary.

NOTE: Do not use organic solvents, boiling water, detergent, strong acid and strong alkali etc. for cleaning.

- Empty the water reservoir and dry it for storage if the ice maker will not be used for a long time.

TROUBLESHOOTING

PROBLEM	POSSIBLE CAUSE	SUGGESTED SOLUTIONS
ADD WATER indicator illuminates.	<ol style="list-style-type: none"> 1. Low water level or lack of water. 2. The water screen at the bottom of water reservoir is blocked. 3. Pump malfunction. 	<ol style="list-style-type: none"> 1. Stop making ice, refill water and then press "ON/OFF" button to restart ice making cycle. 2. Clean the unit. 3. Contact the relevant Customer Care Centre.
ICE FULL indicator illuminates.	<ol style="list-style-type: none"> 1. Ice basket is full and the infrared light is blocked by the ice. 2. Infrared light-emitting diode & light-receiving diode do not work. 	<ol style="list-style-type: none"> 1. Remove the ice from ice basket. 2. Clean foreign objects on the infrared light-emitting diode & light-receiving diode and restart the ice maker. 3. Contact the relevant Customer Care Centre.
ADD WATER and ICE FULL indicators turn on simultaneously.	<ol style="list-style-type: none"> 1. The ice tray is not in the correct position. 2. The ICE FULL condition can not be detected as the infrared light module is interfered by the sunlight. 	<ol style="list-style-type: none"> 1. Unplug the appliance and check if the ice tray is blocked. 2. Unplug the appliance and move it to a place which is not exposed to sunlight, then plug the appliance and activate it again.
The ice made is sticking together.	<ol style="list-style-type: none"> 1. Making ice takes too long. 2. The water temperature in the water tank is too low. 	<ol style="list-style-type: none"> 1. Stop making ice and restart the ice making cycle after the ice melts. 2. Fill the water tank with water ranging from 8°C and 25°C.
The ice making process was correct, but no ice came out.	<ol style="list-style-type: none"> 1. The ambient temperature or water temperature is too high. 2. Refrigerating system leaks. 3. Refrigerating system blocks. 	<ol style="list-style-type: none"> 1. Start the ice making cycle in an environment with an ambient temperature less than 43°C and fill the water reservoir with some cold water. 2. Contact the relevant Customer Care Centre. 3. Contact the relevant Customer Care Centre.

TROUBLESHOOTING

PROBLEM	POSSIBLE CAUSE	SUGGESTED SOLUTIONS
Poor ice making result.	<ol style="list-style-type: none">1. Poor heat dissipation.2. The water temperature is too high.3. The ambient temperature is too high.	<ol style="list-style-type: none">1. Leave a 15cm clearance on all sides of the ice maker for proper ventilation.2. Fill the water tank with water ranging from 8°C and 25°C.3. Operate the ice maker at a environment with an ambient temperature between 10°C and 43°C.

TIPS FOR YOUR ICE MAKER

- Opening the lid for long periods can cause a significant increase of the temperature in the compartments of the appliance.
- If the appliance is left empty for long periods, switch off, defrost, clean, dry, and leave the lid open to prevent mould developing within the appliance.
- It is normal for the compressor and condenser surface to reach temperatures between 70°C and 90°C during operation and surrounding areas may be very hot.
- Due to fast freezing, ice cubes may become opaque. This is due to air becoming trapped in the water and will not affect the quality or taste of the ice.
- Do not use with water that is microbiologically unsafe or of unknown quality. Always use fresh water before starting ice production either at initial installation or after a long shut-off.

MAINTENANCE

If the unit fails to operate efficiently, is broken or other problems arise, unplug and do not operate.

Ask for advice by calling your local after sales service agent or the Customer Care Centre on 1300 556 816 (AU) / 0800 666 2824 (NZ).

WARRANTY

Please refer to the warranty card in the box for warranty information. For any troubleshooting advice, please contact the relative Customer Care Centre below.

Glen Dimplex Australia Pty Ltd
8 Lakeview Drive,
Scoresby 3179, Victoria
Australia
Ph: 1300 556 816

Glen Dimplex New Zealand Ltd
38 Harris Road, East Tamaki,
Auckland 2013
New Zealand
Ph: 0800 666 2824



Recycling: Do not dispose of electrical appliances as unsorted municipal waste. Use separate collection facilities. Contact your local government for information regarding the collection systems available. If electrical appliances are disposed of in landfills or dumps, hazardous substances can leak into the ground water, polluting the food chain and damaging health and wellbeing.

Expanded Polystyrene Disposal: The websites listed below can assist in the responsible disposal of EPS (Expanded Polystyrene) packaging products.

Australia: <https://recyclingnearyou.com.au/polystyrene> and/or <http://epsa.org.au>

New Zealand: <https://greenbusinesshq.com/epsrecycling> and/or

<https://www.plastics.org.nz/environment/recycling-disposal/eps-recycling>

morphy richards®

Glen Dimplex Australia Pty Ltd
8 Lakeview Drive
Scoresby VIC 3179
Phone: 1300 556 816
Email: seasonal.support@glendimplex.com.au
Web: www.morphyrichards.com.au

morphy richards®

Glen Dimplex New Zealand Ltd
1 Ron Driver Place
East Tamaki, Auckland
Phone: 09 274 8265
Email: sales@glendimplex.co.nz
Web: www.morphyrichards.co.nz

© Glen Dimplex Australia. All rights reserved. Material contained in this publication may not be reproduced in whole or in part, without prior permission in writing of Glen Dimplex Australia.