

morphy richards®

illumination



Jug Kettle

Please read and keep these instructions

AUS



www.morphyrichards.com



Health and Safety

The use of any electrical appliance requires the following common sense safety rules.

Please read these instructions carefully before using the product.

- This appliance is not intended for use by persons (including children) with reduced physical, sensory or mental capabilities, or lack of experience and knowledge, unless they have been given supervision or instruction concerning use of the appliance by a person responsible for their safety.
- Children should be supervised to ensure that they do not play with the appliance.
- Cleaning and user maintenance shall not be made by children.
- Keep the appliance and its cord out of reach of children.
- If the mains cable is damaged, it must be replaced by the manufacturer, it's service agent or similarly qualified person in order to avoid a hazard.
- **WARNING: Do not open the lid whilst the water is boiling.**
- **WARNING: Misuse of appliance could cause personal injury.**
- **WARNING: Avoid spillage on the connector.**
- This appliance has an element which may be subject to residual heat after use.
- This appliance is intended to be used in household and similar applications such as: farm houses, by clients in hotels, motels and other residential type environments, and bed and breakfast type environments. It is not suitable for use in staff kitchen areas in shops, offices and other working environments.

Location

- Always locate your appliance away from the edge of the worktop.
- Ensure that the appliance is used on a firm, flat surface.
- Do not use the appliance outdoors or near water.
- **WARNING: Do not place the appliance onto a metal tray or metal surface whilst in use.**

Mains cable

- Do not let the mains cable hang over the edge of the worktop where a child could reach it.
- Do not let the mains cable run across an open space e.g. between a low socket and a table.
- Do not let the mains cable run across a cooker or other hot area which might damage the cable.
- The mains cable should reach from the socket to the base unit without straining the connections.

Personal safety

- Always keep the top of the cordless base dry, especially around the connection area, disconnect the power supply before drying. Allow to dry thoroughly before reconnection to the power supply.
- Do not fill above the MAX mark, otherwise boiling water may be ejected.
- Always pour hot water slowly and carefully without tipping the appliance too fast to prevent splashing and spillage.
- Do not hold the switch in the on position or tamper with the switch to fix it in the on position as this may cause damage to the switch-off mechanism.
- Do not move the kettle while switched on.
- CAUTION: Do not operate the kettle on an inclined plane.
- Do not operate the kettle unless the element is fully immersed.

Other safety considerations

- The use of attachments or tools not recommended or sold by Morphy Richards, may cause fire, electric shock or injury.
- The kettle is only to be used with the stand provided.
- Do not use the appliance for any use other than to boil water.
- The appliance must not be on the base unit when being filled with water.
- Unplug from the outlet when not in use.
- **WARNING: The appliance must not be immersed for cleaning.**

Electrical requirements

Check that the voltage on the rating plate of your appliance corresponds with your house electricity supply which must be A.C. (Alternating Current).

Should the fuse in the mains plug require changing, replace it with a fuse of the same rating as originally fitted.

WARNING: This appliance must be earthed.

AUS

Product Overview

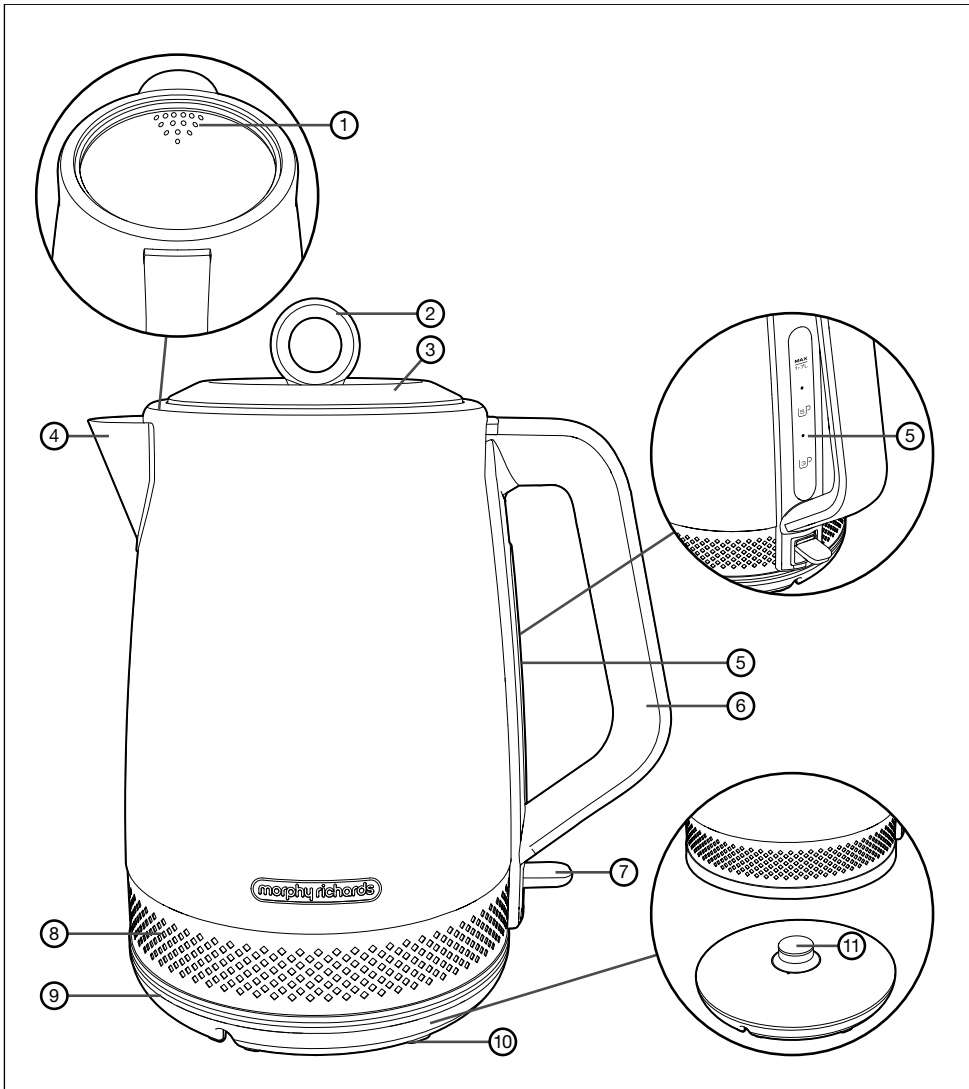

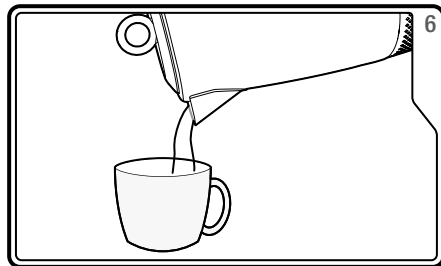
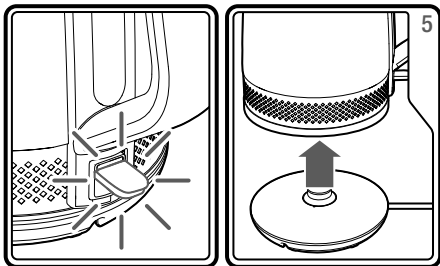
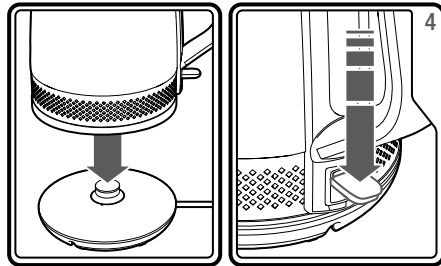
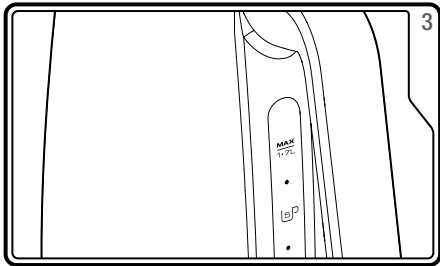
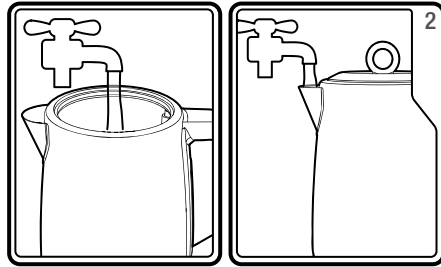
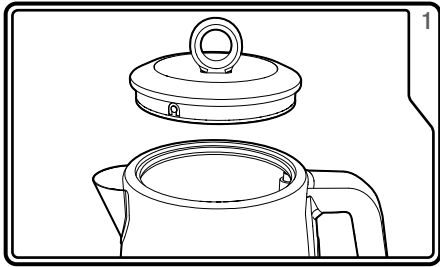

Before first use

Before using the appliance for the first time, fill with water, boil and pour away.

Features

- (1) Integrated Filter
- (2) Lid Handle
- (3) Lid
- (4) Spout
- (5) Water Gauge
- (6) Handle
- (7) On/Off Switch
- (8) Illumination Strip
- (9) Cordless Power Base
- (10) Cord Storage (underneath)
- (11) 360° Connector

Using your kettle

- 1** Lift off the Lid (3).
- 2** Fill the kettle with water, through the Lid opening, or alternatively fill through the Spout (4).
- 3** **IMPORTANT: Do not fill past the MAX line.**
- 4** Place the kettle on the Cordless Power Base (9) and press the On/Off Switch (7). The Illumination Strip (8) and On/Off Switch (7) will illuminate.
- 5** When boiled, the kettle will automatically switch off. Remove from the Cordless Power Base (9).
- 6** Pour the water from the kettle.

CAUTION: Both the kettle and water will be hot.

Cleaning your kettle

- **WARNING: Always disconnect the plug from the mains and allow the kettle to cool before cleaning.**
- Wipe the outside with a damp cloth.
- **IMPORTANT: Do not use abrasive cleaners on the outside of the kettle which may scratch the surface.**

CAUTION: To prevent damage to the appliance, do not use alkaline cleaning agents when cleaning, use a soft cloth and mild detergent.

Descaling

IMPORTANT: As this appliance is fitted with a concealed element it must be descaled regularly. The frequency of descaling depends on usage and the hardness of the water in your area.

Excessive scale can cause the appliance to switch off before boiling and may damage the element, invalidating the warranty.

It is essential that regular descaling takes place. We recommend descaling your kettle every month.

Remove hard scale using a proprietary descaling product suitable for stainless steel, glass or plastic. Please follow the cleaning products instructions carefully.

IMPORTANT: Ensure that the electrical connections are completely dry before using the appliance.

Contact us

Helpline

If you are having a problem with your appliance, please call our Helpline, as we are more likely to be able to help than the store you purchased the item from.

Please have the product name, model number and serial number to hand when you call to help us deal with your enquiry quicker.

Talk To Us

If you have any questions or comments, or want some great tips or recipe ideas to help you get the most out of your products, join us online:

Blog:	www.morphyrichards.co.uk/blog
Facebook:	www.facebook.com/morphyrichardsuk
Twitter:	@loveyourmorphy
Website:	www.morphyrichards.com

MORPHY RICHARDS PRODUCT WARRANTY

This warranty is provided by Glen Dimplex Australia Pty Limited ABN 69 118 275 460 of 8 Lakeview Drive, Scoresby VIC 3179 (Phone number 1300 556 816), or in New Zealand by Glen Dimplex New Zealand Limited, New Zealand registration number 1506305, of 38 Harris Road, East Tamaki, Auckland 2013, New Zealand (Phone number 0800 666 2824) (we, us, our) in respect of the Morphy Richards product which this warranty card has been included in the packaging for or otherwise supplied with (the Morphy Richards product).

1 Morphy Richards express warranty

Subject to the exclusions below, we warrant that the Morphy Richards product will be free from defects caused by faulty workmanship and materials within:

- (a) in the case of the Morphy Richards products used for personal, domestic or household purposes, a period of 24 months from the date the Morphy Richards product is purchased as a brand new product from a retailer located in Australia or New Zealand; and
- (b) in the case of the Morphy Richards product used for purposes other than personal, domestic or household purposes (including business or commercial use), a period of 12 months from the date the Morphy Richards product is purchased as a brand new product from a retailer located in Australia or New Zealand. Morphy Richards products are designed and intended for domestic use.

This express warranty is personal to the first person who acquires the Morphy Richards product from the relevant retailer and claims under this warranty cannot be made by anyone other than this person.

The benefits conferred by this express warranty are in addition to the Consumer Guarantees referred to in section 3 and any other statutory rights you may have under the Australian Consumer Law, the New Zealand Consumer Guarantees Act and/or other applicable laws.

2 Warranty exclusions

This express warranty does not apply where:

- (a) the Morphy Richards product has been installed, used or operated otherwise than in accordance with the product manual or other similar documentation provided to you with the Morphy Richards product;
- (b) the Morphy Richards product requires repairs due to damage resulting from accident, misuse, incorrect installation, improper liquid spillage, cleaning or maintenance, unauthorised modification, use on an incorrect voltage, power surges and dips, voltage supply problems, tampering or unauthorised repairs by any persons, use of defective or incompatible accessories or exposure to abnormally corrosive conditions;
- (c) the repair relates to the replacement of consumable parts such as fuses in plugs and bulbs or any other parts of the Morphy Richards product which require routine replacement;
- (d) you are unable to provide us with reasonable proof of purchase for the Morphy Richards product;
- (e) the breakdown occurs after the expiry of the express warranty period set out in section 1; or

(f) the Morphy Richards product was not purchased in Australia or New Zealand as a brand new product.

3 Consumer Guarantees

Our goods come with guarantees that cannot be excluded under the Australian Consumer Law. You are entitled to a replacement or refund for a major failure and for compensation for any other reasonably foreseeable loss or damage. You are also entitled to have the goods repaired or replaced if the goods fail to be of acceptable quality and the failure does not amount to a major failure.

If you acquired the goods in New Zealand, similar provisions of the Consumer Guarantees Act 1993 may apply, but may be excluded if you acquired the goods for the purpose of a business.

4 How to make a claim

You may make a claim under this warranty by visiting our website at (www.morphyrichards.com.au in Australia, www.morphyrichards.co.nz in New Zealand), contacting our customer care line (1300 556 816 in Australia, 0800 666 2824 in New Zealand) or visiting a Morphy Richards service centre.

To make a valid claim under this warranty, you must:

- (a) lodge the claim with us as soon as possible and no later than 14 days after you first become aware of the breakdown;
- (b) provide us with the Morphy Richards product serial number;
- (c) provide us with reasonable proof of purchase for the Morphy Richards product; and
- (d) if required by us, provide us (or any person nominated by us) with access to the premises at which the Morphy Richards product is located at times nominated by us (so that we can inspect the Morphy Richards product).

5 Warranty claims

If you make a valid claim under this warranty and none of the exclusions set out in section 2 apply, we will, at our election, either repair the Morphy Richards product or replace the Morphy Richards product with a product of identical specification (or where the product is superseded or no longer in stock, with a product of as close a specification as possible).

Goods presented for repair may be replaced by refurbished goods of the same type rather than being repaired. Refurbished parts may be used to repair the goods.

Morphy Richards products are designed and supplied for normal domestic use. We will not be liable to you under this warranty for business loss or damage of any kind whatsoever.

6 Costs of warranty claim

Where you make a claim under this warranty, a Morphy Richards authorised repairer may need to attend your premises to inspect the Morphy Richards product. If the Morphy Richards product is located in Australia, we may charge you a service call fee if a repairer will be required to travel more than 30 kilometers from the place of purchase. For further information, please contact Glen Morphy Richards on 1300 556 816 in Australia or 0800 666 2824 in New Zealand. Alternatively, visit our website at www.morphyrichards.com.au in Australia or www.morphyrichards.co.nz in New Zealand.



AUS **Glen Dimplex Australia**
8 Lakeview Drive, Scoresby, Victoria 3179
T : 1300 556 816
E : sales@glendimplex.com.au
www.morphyrichards.com.au

NZ **Glen Dimplex New Zealand**
38 Harris Road, East Tamaki, Auckland, New Zealand
T : 0800 666 2824
E : sales@glendimplex.co.nz







morphy richards®

KT108020MAUS Rev 3 05/21

www.morphyrichards.com

