

morphyrichards®

smart ideas for your home

Microwave Oven

INSTRUCTION MANUAL

Model: MRMWO34GC

Read these instructions carefully before
using your microwave oven.

STORE THESE INSTRUCTIONS CAREFULLY

www.morphyrichards.com.au

PRECAUTIONS TO AVOID POSSIBLE EXPOSURE TO EXCESSIVE MICROWAVE ENERGY

- Do not attempt to operate this oven with the door open since this can result in harmful exposure to microwave energy. It is important not to break or tamper with the safety interlocks.
- Do not place any object between the oven front face and the door or allow spatter/matter or cleaner residue to accumulate on sealing surfaces.
- **WARNING:** If the door or door seals are damaged, the oven must not be operated until it has been repaired by a competent person.

ADDENDUM

If the apparatus is not maintained in a good state of cleanliness, its surface could be degraded and affect the lifespan of the apparatus and lead to a dangerous situation.

SPECIFICATIONS

Model:	MRMWO34GC
Rated Voltage:	230-240V~50Hz
Rated Input Power (Microwave):	1550W
Rated Output Power (Microwave):	1000W
Rated Output (Grill):	1100W
Rated Output (Convection):	2100W
Oven Capacity:	34L
Turntable Diameter:	315mm
External Dimensions (HxWxD):	314 X 520 X 510mm
Net Weight:	Approx 21kg

IMPORTANT SAFETY INSTRUCTIONS

WARNING

To reduce the risk of fire, electric shock, injury to persons or exposure to excessive microwave oven energy when using your appliance, follow basic precautions, including the following:

- Read and follow the specific: “**PRECAUTIONS TO AVOID POSSIBLE EXPOSURE TO EXCESSIVE MICROWAVE ENERGY**”.
- This appliance can be used by children aged from 8 years and above and persons with reduced physical, sensory or mental capabilities or lack of experience and knowledge if they have been given supervision or instruction concerning use of the appliance in a safe way and understand the hazards involved. Children shall not play with the appliance. Cleaning and user maintenance shall not be made by children unless they are older than 8 and supervised. Children less than 8 years of age shall be kept away unless continuously supervised.
- Keep the appliance and its cord out of reach of children less than 8 years.
- If the supply cord is damaged, it must be replaced by the manufacturer, its service agent or similarly qualified persons in order to avoid a hazard. (For appliance with type Y attachment)
- **WARNING:** Ensure that the appliance is switched off before replacing the lamp to avoid the possibility of electric shock.
- **WARNING:** It is hazardous for anyone other than an authorised repairer/technician to carry out any service or repair operation that involves the removal of a cover which gives protection against exposure to microwave energy.
- **WARNING:** Liquids and other foods must not be heated in sealed containers since they are liable to explode.

- Do not heat food in plastic or paper containers, due to the possibility of ignition.
- Only use utensils that are suitable for use in microwave ovens.
- If smoke is emitted, switch off or unplug the appliance and keep the door closed in order to stifle any flames.
- Microwave heating of beverages can result in delayed eruptive boiling, therefore care must be taken when handling the container.
- The contents of feeding bottles and baby food jars shall be stirred or shaken and the temperature checked before consumption, in order to avoid burns.
- Eggs in their shell and whole hard-boiled eggs should not be heated in microwave ovens since they may explode, even after microwave heating has ended.
- The oven should be cleaned regularly and any food deposits removed.
- Failure to maintain the oven in a clean condition could lead to deterioration of the surface that could adversely affect the life of the appliance and possibly result in a hazardous situation.
- The appliance must not be installed behind a decorative door in order to avoid overheating. (This is not applicable for appliances with decorative door.)
- Only use the temperature probe recommended for this oven.(for ovens provided with a facility to use a temperature-sensing probe.)
- The microwave oven shall not be placed in a closed cabinet.
- The microwave oven is intended for heating food and beverages. Drying of food or clothing and heating of warming pads, slippers, sponges, damp cloth and similar may lead to risk of injury, ignition or fire.

- Metallic containers for food and beverages are not allowed during microwave cooking.
- The appliance shall not be cleaned with a steam cleaner.
- The appliance is intended to be used freestanding.
- The rear surface of appliances shall be placed against a wall.
- Steam cleaner is not to be used.
- Surface of a storage drawer can get hot.
- Do not use harsh abrasive cleaners or sharp metal scrapers to clean the oven door glass since they can scratch the surface, which may result in shattering of the glass.
- **WARNING:** The appliance and its accessible parts become hot during use. Care should be taken to avoid touching heating elements. Children less than 8 years of age shall be kept away unless continuously supervised.
- During use the appliance becomes hot. Care should be taken to avoid touching heating elements inside the oven.
- **WARNING:** Accessible parts may become hot during use. Young children should be kept away.
- **WARNING:** Children should only use the oven under adult supervision due to the temperatures generated.

READ CAREFULLY AND KEEP FOR FUTURE REFERENCE

DANGER

ELECTRIC SHOCK HAZARD

Touching some of the internal components can cause serious personal injury or death. Do not disassemble this appliance.

WARNING

ELECTRIC SHOCK HAZARD

Improper use of the grounding can result in electric shock.

Do not plug into an outlet until appliance is properly installed and grounded.

This appliance must be grounded. In the event of an electrical short circuit, grounding reduces the risk of electric shock by providing an escape wire for the electric current.

This appliance is equipped with a cord having a grounding wire with a grounding plug. The plug must be plugged into an outlet that is properly installed and grounded.

Consult a qualified electrician or serviceman if the grounding instructions are not completely understood or if doubt exists as to whether the appliance is properly grounded.

If it is necessary to use an extension cord, use only a 3-wire.

1. A short power-supply cord is provided to reduce the risks resulting from becoming entangled in or tripping over a longer cord.
2. If a long cord set or extension cord is used:
 - The marked electrical rating of the cord set or extension cord should be at least as great as the electrical rating of the appliance.
 - The extension cord must be a grounding-type 3-wire cord.
 - The long cord should be arranged so that it will not drape over the counter top or tabletop where it can be pulled on by children or tripped over unintentionally.

CLEANING

BE SURE TO UNPLUG THE APPLIANCE FROM THE POWER SUPPLY.

1. Clean the cavity of the oven after using with a slightly damp cloth.
2. Clean the accessories in the usual way in soapy water.
3. The door frame and seal and neighbouring parts must be cleaned carefully with a damp cloth when they are dirty.
4. Do not use harsh abrasive cleaners or sharp metal scrapers to clean the oven door glass since they can scratch the surface, which may result in shattering of the glass.
5. Cleaning Tip: For easier cleaning of the cavity walls that the food cooked can touch: Place half a lemon in a bowl, add 300ml
6. (1/2 pint) water and heat on 100% microwave power for 10 minutes. Wipe the oven clean using a soft, dry cloth.

UTENSILS CAUTION

PERSONAL INJURY HAZARD

It is hazardous for anyone other than an authorised repairer/technician to carry out any service or repair operation that involves the removal of a cover which gives protection against exposure to microwave energy.

See the instructions on “Materials you can use in microwave oven or to be avoided in microwave oven.” There may be certain non-metallic utensil/container that are not safe to use for microwaving. If in doubt, you can test the utensil/container in question following the procedure below.

UTENSILS TEST

1. Fill a microwave-safe container with 1 cup of cold water (250ml) along with the utensil/container in question.
2. Cook on maximum power for 1 minute.
3. Carefully feel the utensil. If the empty utensil/container is warm, do not use it for microwave cooking.
4. Do not exceed 1 minute cooking time.

MATERIALS YOU CAN USE IN MICROWAVE OVEN

Utensils	Remarks
Browning dish	Follow manufacturer's instructions. The bottom of browning dish must be at least 3/16 inch (5mm) above the turntable. Incorrect usage may cause the turntable to break.
Dinnerware	Microwave-safe only. Follow manufacturer's instructions. Do not use cracked or chipped dishes.
Glass jars	Always remove lid. Use only to heat food until just warm. Most glass jars are not heat resistant and may break.
Glassware	Heat-resistant oven glassware only. Make sure there is no metallic trim. Do not use cracked or chipped dishes.
Oven cooking bags	Follow manufacturer's instructions. Do not close with metal tie. Make slits to allow steam to escape.
Paper plates and cups	Use for short-term cooking/warming only. Do not leave oven unattended while cooking.
Paper towels	Use to cover food for reheating and absorbing fat. Use with supervision for a short-term cooking only.
Parchment paper	Use as a cover to prevent splattering or a wrap for steaming.
Plastic	Microwave-safe only. Follow the manufacturer's instructions. Should be labeled "Microwave Safe". Some plastic containers soften, as the food inside gets hot. "Boiling bags" and tightly closed plastic bags should be slit, pierced or vented as directed by package.
Plastic wrap	Microwave-safe only. Use to cover food during cooking to retain moisture. Do not allow plastic wrap to touch food.
Thermometers	Thermometers Microwave-safe only (meat and candy thermometers).
Wax paper	Wax paper Use as a cover to prevent splattering and retain moisture.

MATERIALS TO BE AVOIDED IN MICROWAVE OVEN

Utensils	Remarks
Aluminum tray	May cause arcing. Transfer food into microwave-safe dish.
Food carton with metal handle	May cause arcing. Transfer food into microwave-safe dish.
Metal or metal trimmed utensils	Metal shields the food from microwave energy. Metal trim may cause arcing.
Metal twist ties	May cause arcing and could cause a fire in the oven.
Paper bags	May cause a fire in the oven.
Plastic foam	Plastic foam may melt or contaminate the liquid inside when exposed to high temperature.
Wood	Wood will dry out when used in the microwave oven and may split or crack.

SETTING UP YOUR OVEN

NAMES OF OVEN PARTS AND ACCESSORIES

Remove the oven and all materials from the carton and oven cavity.

Your oven comes with the following accessories:

Glass tray	1
Turntable ring assembly	1
Instruction Manual	1

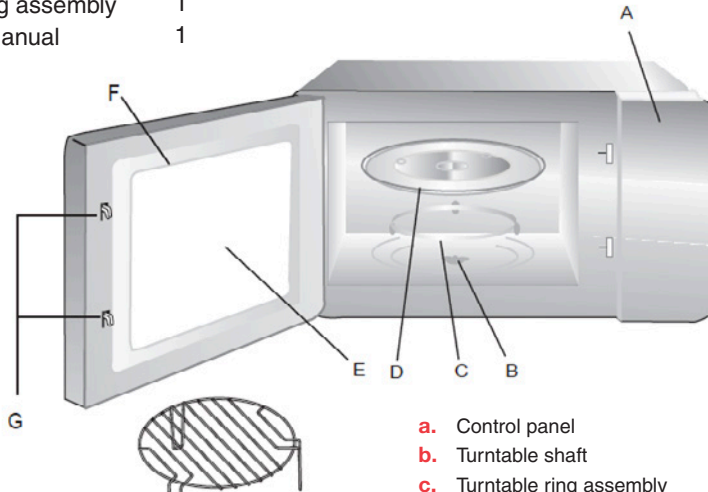

Grill Rack (Can not be used in microwave function and must be placed on the glass tray)

- a. Control panel
- b. Turntable shaft
- c. Turntable ring assembly
- d. Glass tray
- e. Observation window
- f. Door assembly
- g. Safety interlock system

TURNTABLE INSTALLATION

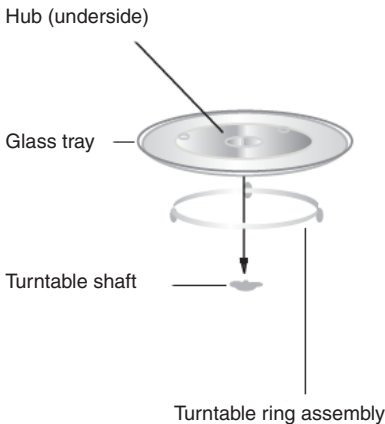

- a. Never place the glass tray upside down. The glass tray should never be restricted.
- b. Both glass tray and turntable ring assembly must always be used during cooking.
- c. All food and containers of food are always placed on the glass tray for cooking.
- d. If glass tray or turntable ring assembly cracks or breaks, contact your nearest authorized service center.

COUNTERTOP INSTALLATION

Remove all packing material and accessories. Examine the oven for any damage such as dents or broken door. Do not install if oven is damaged.

Cabinet: Remove any protective film found on the microwave oven cabinet surface. Do not remove the light brown Mica cover that is attached to the oven cavity to protect the magnetron.

INSTALLATION

1. Select a level surface that provide enough open space for the intake and/or outlet vents.

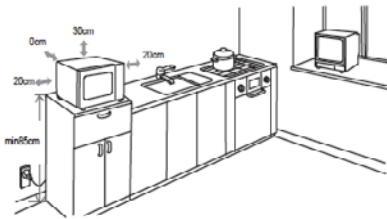

2. Plug your oven into a standard household outlet. Be sure the voltage and the frequency is the same as the voltage and the frequency on the rating label.

WARNING:

Do not install oven over a range cooktop or other heat-producing appliance. If installed near or over a heat source, the oven could be damaged and the warranty would be void.

- The minimum installation height is 85cm.
- The rear surface of appliance shall be placed against a wall.
- Leave a minimum clearance of 30cm above the oven, a minimum clearance of 20cm is required between the oven and any adjacent walls.
- Do not remove the legs from the bottom of the oven.
- Blocking the intake and/ or outlet openings can damage the oven.
- Place the oven as far away from radios and TV as possible. Operation of microwave oven may cause interference to your radio or TV reception.

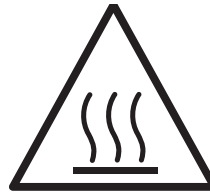

THE ACCESSIBLE SURFACE MAY BE HOT DURING OPERATION.

OPERATION INSTRUCTION

CLOCK SETTINGS

When the microwave oven is electrified, the oven will display "0:00", buzzer will ring once. The input time should be within 0:00--23:59 (24 Hour).

Example: To set 12:12 .

1. Press "**KITCHEN TIMER /CLOCK**" twice, "00:00" will flash.
2. Press the number buttons of "1", "2", "1", "2" in order.
3. Press "**KITCHEN TIMER /CLOCK**" to finish clock setting. ":" will flash, and the time will light.

Note:

- 1) If the clock is not set, it will not function when powered.
- 2) During the process of clock setting, if you press "**STOP/CLEAR**" or if no operation in 1 minute, the oven will go back to the previous status automatically.

MICROWAVE COOKING

Select different microwave power level and set cooking time as you wish. There are five power levels available for choosing. Keep on pressing "**MICROWAVE**" to choose the power.

Example: If you want to use 80% microwave power to cook for 10 minutes, you can operate the oven as the following steps.

1. Press "**MICROWAVE**" once, "P100" will flash.
2. Press "**MICROWAVE**" once again to choose 80% power, the oven will display "P80".
3. Press "**START/+30SEC.**" to confirm the power.
4. Press the number buttons of "1", "0", "0", "0" in order, the oven will display "10:00".
5. Press "**START/+30SEC.**" to start cooking.

Note: "MICROWAVE" Cooking power options

Press " MICROWAVE " button	Display	Microwave Power
1 time	P100	100%
2 times	P80	80%
3 times	P50	50%
4 times	P30	30%
5 times	P10	10%

KITCHEN TIMER

1. Press "**KITCHEN TIMER/CLOCK**" once, LED will display 00:00.
2. Press the number buttons and enter the correct time. (the maximum cooking time is 99 minutes and 99 seconds)
3. Press "**START/+30SEC.**" to confirm setting.
4. When the kitchen time is reached, the buzzer will ring 5 times. Then turn back to waiting state. If the clock is set (24-hour system), LED will display the current time.

Note: The kitchen timer is different from 24-hour system, Kitchen Timer is a timer.

GRILL COOKING

Example: If you want to use grill function to cook for 35 minutes, you can operate the oven as the following:

1. Press the "**GRILL.**" button once, the oven will display "G-1".
2. Press the "**START/+30SEC.**" button to confirm the setting.
3. Press the number buttons of "3", "5", "0", "0" in order, the oven will display "35:00".
4. Press the "**START/+30SEC.**" button to start cooking.

CONVECTION COOKING (WITH PREHEATING FUNCTION)

The convection cooking can let you to cook the food as a traditional oven. Microwave is not used. It is recommended that you should preheat the oven to the appropriate temperature before placing the food in the oven.

1. Press the "**CONVEC.**" button once, "150" will flash. Press the "**CONVEC**" button several times to select the temperature from 150° C to 240° C.
2. Press the "**START/+30SEC.**" button to confirm the temperature.
3. Press the "**START/+30SEC.**" again to start preheating. The temperature figure will flash when reach to the temperature in advance and buzzer will ring twice to remind you to put the food into the oven.
4. Press the number buttons to set the cooking time.
5. Press the "**START/+30SEC.**" button to start cooking.

Note:

- Cooking time cannot be input until the preheating temperature is reached.
- When the temperature is reached, door must be opened to input the cooking time.
- If the time is not input in 5 minutes, the oven will stop preheating. The buzzer sounds five times and turns back to waiting.

CONVECTION COOKING (WITHOUT PREHEATING FUNCTION)

1. Press the “**CONVEC.**” button once, “150°” will flash. Press the “**CONVEC.**” button several times to select the temperature from 150° C to 240° C.
2. Press the “**START/+30SEC.**” button to confirm the temperature.
3. Press the number buttons to set the cooking time.
4. Press the “**START/+30SEC.**” button to start cooking.

COMBINATION COOKING

Example: If you want to use combination to cook (C-1) for 30 minutes, you can operate the oven as following steps.

1. Press the “**COMBI.**” button once, “C-1” will flash.
2. Press the “**START/+30SEC.**” button to confirm the setting.
3. Press the number buttons of “3”, “0”, “0”, “0” in order, the oven will display “30:00”.
4. Press the “**START/+30SEC.**” button to start cooking.

Note: “COMBI” Cooking options

Press “COMBI” button	Display	Microwave Power	Grill Power	Convection Power
1 time	C-1	●		●
2 times	C-2	●	●	
3 times	C-3		●	●
4 times	C-4	●	●	●

DEFROST BY TIME

1. Press “**DEFROST.**” once, the oven will display “D-01”.
2. Press “**START/+30SEC.**” button to confirm the setting.
3. Input the figure of the time of cooking.
(The maximum cooking time is 99 minutes and 99 seconds.)
4. Press “**START/+30SEC.**” button to start defrosting.

DEFROST BY WEIGHT

1. Press **"DEFROST."** pad twice, the oven will display "D-02".
2. Press **"START/+30SEC."** button to confirm the setting.
3. Input the figure of the weight of food.
(The input figure of the weight should be within 100--2000g)
4. Press **"START/+30SEC."** button to start defrosting.

DEFROST GROUND MEAT

1. Press **"DEFROST."** pad three times, the oven will display "D-03".
2. Press **"START/+30SEC."** button to confirm the setting.
3. Input the figure of the weight of food.
(The input figure of the weight should be within 100--2000g)
4. Press **"START/+30SEC."** button to start defrosting.

DEFROST SEAFOOD

1. Press **"DEFROST."** pad 4 times, the oven will display "D-04".
2. Press **"START/+30SEC."** button to confirm the setting.
3. Input the figure of the weight of food.
(The input figure of the weight should be within 100--2000g)
4. Press **"START/+30SEC."** button to start defrosting.

AUTO MENU COOKING

The numeral pads 0—9 are matching with ten different subjects respectively;

Pad	Cook	Pad	Cook	Pad	Cook	Pad	Cook
1	VEGETABLE	4	PASTA	7	ROAST CHICKEN	0	PIZZA
2	FISH	5	POTATO	8	BREAD		
3	MEAT	6	SOUP	9	CAKE		

Example : Cooking vegetable of 350g:

1. Press **"VEGETABLE."** button. Oven will display "150",
2. Press **"VEGETABLE."** button again to choose weight, 300g, 500g
3. Press **"START/+30SEC."** to start cooking.
4. Note: Cake menu is under convection cooking with 160-warm-up function, and you should preheat first following the auto menu operation, when the oven reaches the temperature, it will stop working and sound to remind opening the door to put cake in, then press **"START/+ 30SEC."** to start cooking.

AUTO MENU CHART

Menu	Weight	Press Times	Display
VEGETABLE	150g	Once	150
	350g	Twice	350
	500g	3 times	500
FISH	150g	Once	150
	250g	Twice	250
	350g	3 times	350
	450g	4 times	450
	650g	5 times	650
MEAT	150g	Once	150
	300g	Twice	300
	450g	3 times	450
	600g	4 times	600
PASTA	50g (with cold water 450)	Once	50
	100g (with cold water 800g)	Twice	100
	150g (with cold water 1200g)	3 times	150
POTATO	1 (approximately 230g)	Once	1
	2	Twice	2
	3	3 times	3
SOUP	200ml	Once	200
	400ml	Twice	400
	600ml	3 times	600
ROAST CHICKEN	500g	Once	500
	750g	Twice	750
	1000g	3 times	1000
	1200g	4 times	1200
BREAD	50g	Once	50
	100g	Twice	100
	150g	3 times	150
CAKE	475g	Once	475
PIZZA	200g	Once	200
	300g	Twice	300
	400g	3 times	400

MEMORY

1. Press "**MEMORY.**" button one to three times to set memory "1", memory "2" or memory "3" program, and the oven will display "1", "2" or "3".
2. Set one or two stages to program you want.
(Reheat or Auto menu cannot be set as memory program).

Example:

- Press "**MICROWAVE.**" once to choose 100% microwave power;
 - Press number buttons "1", "0", "0", "0" in order to adjust the cooking time;
3. Press "**MEMORY.**" button to save the memory program chosen, or press "**START/+30SEC.**" to start cooking and save the program automatically.
 4. Next time when you want to cook with the memory program which has been set, you just only need to press "**MEMORY.**" button to choose the program wanted and then press "**START/+30SEC.**" to start cooking.

Note: If the electricity is cut off, the procedure that has been saved will be canceled.

MULTI STAGE COOKING

A maximum of two stages of cooking can be set. If one of the stages is defrosting, it should be put in the first stage automatically, and auto menu should not be set here. The buzzer will ring once after each stage and the next stage will begin.

Example: If you want to cook the food with 100% microwave power for 10 minutes+ 80% microwave power for 15 minutes. Do it as following:

1. Press "**MICROWAVE.**" once to choose 100% microwave power;
2. Press "**START/+30SEC.**" button to confirm the setting.
3. Press number buttons "1", "0", "0", "0" in order to adjust the cooking time;
4. Press "**MICROWAVE.**" twice to choose 80% microwave power;
5. Press "**START/+30SEC.**" button to confirm the setting.
6. Press number buttons "1", "5", "0", "0" in order to adjust the cooking time;
7. Press "**START/+30SEC.**" to start cooking.

NOTE: Kitchen Timer, Auto Menu, Speedy Cooking or Preheating cannot be set as one of the multi-stage.

QUICK START

When the oven is in the waiting states, press "**START/+30SEC.**" button to start with full microwave power for 30 seconds (the maximum setting is 99 minutes and 99 seconds).

Note: This can NOT be set as one stage of the multi-stage cooking.

REHEAT

1. Press “**REHEAT.**” pad , the “H-01” will flash and “**AUTO.**” indicator will light
(Press the “**REHEAT.**” pad several times to select the cooking program you wanted.)
2. Press “**START/+30SEC.**” button to confirm.
3. Press the “**REHEAT.**” pad several times to select the weight of the cooking food.
4. Press “**START/+30SEC.**” button to start cooking.

REHEAT CHART

Menu	Weight	Display
H-01 (AUTO REHEAT)	150g	150
	250g	250
	350g	350
	450g	450
	600g	600
H-02 (DINNER PLATE)	250g	250
	350g	350
	450g	450
H-03 (COFFEE)	1 cup (approximately 240g)	1
	2 cups (approximately 480g)	2
	3 cups (approximately 720g)	3
H-04 (ROLL)	1 (approximately 70g)	1
	2 (approximately 140g)	2
	3 (approximately 210g)	3

INQUIRING FUNCTION

1. In cooking state, press “**COMBI.**”, “**MICROWAVE.**”, or “**CONVEC.**”, and the current power will be displayed for 3 seconds.
2. In cooking state, press “**CLOCK/KITCHEN TIMER.**” to inquire the time. The time will flash for 3 seconds.

LOCK-OUT FUNCTION FOR CHILDREN

LOCK:

In waiting state, press “**STOP/CLEAR**”, there will be a long “beep”.

3 seconds later, there will be 2 short beeps. And a button indicator will light.

The oven will display “ [_ _ _] ” or current time.

LOCK QUITTING:

In locked state, press “**STOP/CLEAR**”, there will be a long “beep”.

3 seconds later, there will be 2 short beeps. And a button indicator will go out. The oven will display “0:00” or current time.

SPECIFICATION

1. In waiting state, the oven will display clock and “ : ” will flash.
2. In function setting state, the oven will display the related setting.
3. In the operation and suspending state, the oven will display the residual cooking time.
4. During microwave, grill, combination or convection cooking, 30 seconds can be added by pressing “**START/+30SEC.**” button.

TROUBLE SHOOTING

Normal

Microwave oven interfering TV reception	Radio and TV reception may be interfered with when microwave oven is operating. It is similar to the interference of small electrical appliances, like mixer, vacuum cleaner, and electric fan. It is normal.
Dim oven light	In low power microwave cooking, oven light may become dim. It is normal.
Steam accumulating on door, hot air out of vents	In cooking, food can release steam. Most escape from vents, but some may accumulate on cool place like oven door. It is normal.
Oven started accidentally with no food in	It is very dangerous to run the unit without any food inside.

Trouble	Possible Cause	Remedy
Oven cannot be started	1. Power cord not plugged in tightly	Unplug. Then plug in again after 10 seconds
	2. Fuse blowing or circuit breaker works	Replace fuse or reset circuit (repaired by professional personnel of our company)
	3. Trouble with outlet	Test outlet with other appliances
Oven does not heat	4. Door not closed well	Close door



morphy richards

Glen Dimplex Australia Pty Ltd
1340 Ferntree Gully Road
Scoresby VIC 3179
Phone: 1300 556 816
Email: sales@glendimplex.com.au
Web: www.morphyrichards.com.au