

---

**morphyrichards®**



**2- and 4-slice contemporary toasters**

Please read and keep these instructions



### Important safeguards

- Read all instructions.
- Always locate your toaster away from the edge of the worktop.
- Ensure that the toaster is used on a firm, flat, heat resistant surface.
- Ensure that sufficient space is left above and around all sides of your toaster to allow air to circulate.
- IMPORTANT: Do not use too close to curtains, draperies, walls, cupboards and other flammable materials.
- Do not use underneath cupboards.
- Do not use outdoors.
- The mains lead should reach from the socket to the toaster without straining the connections. Reduce the length of excess lead by using the cord storage facility.
- Do not let the mains lead hang over the edge of the worktop where a child could reach it.
- Do not let the lead run across an open space e.g. between a low socket and table.
- Do not let the lead run across a cooker or other hot area which might damage the cable.
- Do watch your toaster during use.
- **WARNING: Do not touch the top of the toaster or other hot parts during or after use - use handles or knobs.**
- **WARNING: Do not insert oversize foods, metal foil packages or utensils into the toaster.**
- **WARNING: Do not attempt to dislodge food when toaster is plugged in and never insert cooking utensils into slots.**
- IMPORTANT: Do not place bread or other items on top of the slots as this may damage your toaster and creates a fire hazard.
- Never allow a child to operate this appliance.
- Children are vulnerable in the kitchen particularly when unsupervised and if appliances are being used or cooking is being carried out.
- Teach children to be aware of dangers in the kitchen, warn them of the dangers of reaching up to areas where they cannot see properly or should not be reaching.
- Do not operate with a damaged cord or plug, or after a malfunction.
- Do not attempt repairs - the appliance contains no user-serviceable parts. Call our helpline for advice.
- Do not use accessories not recommended by the manufacturer.
- Do not place on or near a hot gas electric burner or in a heated oven.
- Do not immerse cord, plug or toaster in water or other liquid.
- Unplug from outlet when not in use and when cleaning.
- Do not move the appliance whilst hot.
- Young children should be supervised to ensure they do not play with the appliance.
- This appliance is not intended to be used by young children or infirm persons without supervision.
- If the supply cord is damaged it must be replaced by the manufacturer or its service agent or similarly qualified person in order to avoid a hazard.

### Getting the best from your new toaster...

#### Safety first

- This appliance is not intended for use by persons (including children) with reduced physical, sensory or mental capabilities, or lack of experience and knowledge, unless they have been given supervision or instruction concerning use of the appliance by a person responsible for their safety.

- Do not touch the metal top or sides of the toaster during or after use as these get very hot.
- **Empty the crumb tray regularly**
- To clean away any crumbs that accumulate after use.
- **In order to achieve uniform browning**
- Wait a minimum of 30 seconds between each toasting, so that the control can automatically reset.

### Features

- 1 Bun warmer rack (x 2 on 4 slice)
- 2 Bread slots
- 3 Bread carriage lever with high-lift feature
- 4 Re-heat button
- 5 Cancel button
- 6 Frozen bread button
- 7 Electronic variable browning control
- 8 Cord storage
- 9 Removable crumb tray/s
- 10 2/4 slice selection switch (4 slice only)

### Before first use

Before using the toaster for the first time operate the toaster without bread in a ventilated room.

- The bread carriage levers **3** will not stay down unless the toaster is connected to the mains supply.
- As with all new electric heating elements, your toaster emits a 'new' smell when it is first switched on which is quite normal.

### Toasting

- 1 Set the 2/4 slice selection switch **10** (applicable on 4 slice model only).
- 2 Select the desired level of browning on the browning control **7** marked 1 to 8. The setting required will vary according to the moisture content and thickness of bread. For best results ensure that the bread slices are of even thickness, freshness and size. Remember that stale bread toasts more rapidly than fresh and thin bread toasts quicker than thick. See additional points for more information.
- 3 After selecting the desired level, place your bread in the slots and depress the bread carriage lever downwards until it locks.

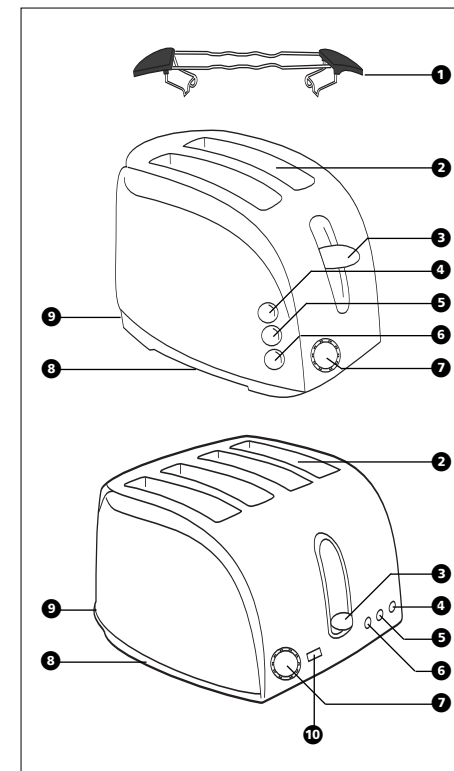

- 4 After the set time has been reached the bread will pop-up automatically ready for removal from the slots. The bread carriage lever will have returned to its upper position and the heating element will have switched off.

- If the bread in your toaster becomes jammed disconnect your toaster at the socket, allow it to cool, then remove the bread.
- When not in use, remove the plug from the mains socket.
- Allow the toaster to cool fully before putting away.

**WARNING: Do not wrap the cable around the main body of the appliance during or after use.**

### Using the re-heat button

If your toast has popped up and gone cold, the toaster offers a re-heat facility. To use, depress the

bread carriage lever and press the re-heat button 4 immediately. The button will illuminate and the toaster will operate for a short period re-heating the bread.

### **Using the cancel button**

If you wish to interrupt the toasting process, press the cancel button 5.

### **Using the frozen button**

To toast frozen bread, do not adjust the browning control, place the bread normally in the bread slots, depress the bread carriage lever and press the frozen bread button 6. The button will illuminate and the toaster will automatically toast for an extended period.

### **2/4 slice selection switch**

*(4 slice model only)*

When only two slices of toast are required, switch off the heating elements in two of the bread slots by switching the 2/4 slice selection switch, only the two left-hand bread slots will toast.

### **Using the bun warmer**

Clip the bun rack(s) 1 onto the slots on top of the toaster, ensuring it is securely placed. Set the browning control to between 1 and 3. Depress the bread carriage lever until it holds down. Wait for the toaster to switch off automatically or press the cancel button to switch the toaster off before removing the buns. Take care not to touch the metal bun rack as this will be hot.

### **Additional points**

- In order to achieve uniform browning, we recommend you wait a minimum of 30 seconds between each toasting, so that the control can automatically be reset.
- If toasting one slice only, you may need to adjust the browning control to a slightly lower setting.
- Note you will also notice a slight variation in toast colour on one side of a single slice.
- Stale bread toasts more rapidly than fresh bread. Therefore, the browning

control should be set at a lower setting than usual.

- All sorts of bread can be used as well as teacakes, small rolls etc. Slices should not however be so thick as to cause burning or jamming within the bread slots.
- When toasting two or more slices it is recommended they are of equal size and freshness.
- Allow the toaster to cool fully before putting away.

### **Cleaning and maintenance**

- 1 After use and before cleaning, switch off at the mains, remove the plug from the wall socket and wait for the toaster to cool.
  - 2 Wipe the outside of the toaster with a damp cloth only and dry with another cloth or tissue.
- Never use metal polish or coarse scouring agents and never immerse your toaster in any sort of liquid.
  - Never use any pointed or sharp articles for cleaning the inside, otherwise the heating element will be damaged.
  - Never use a brush or push your fingers or metal objects down the slots.

### **Crumb tray/s**

**WARNING: Crumbs will accumulate in the crumb tray and could catch fire if not emptied periodically.**

When the toaster has cooled down completely, tap the sides of the case lightly to dislodge any crumbs lodged in the toasting chamber and remove the crumb trays 3. Empty the tray and replace it.

Never operate the toaster without the crumb trays fitted.

### **YOUR TWO YEAR GUARANTEE**

It is important to retain the retailers receipt as proof of purchase. Staple your receipt to this back cover for future reference.

Please quote the following information if the product develops a fault. These numbers can be found on the base of the product.

Model no.

Serial no.

All Morphy Richards products are individually tested before leaving the factory. In the unlikely event of any appliance proving to be faulty within 28 days of purchase it should be returned to the place of purchase for it to be replaced.

If the fault develops after 28 days and within 24 months of original purchase, you should contact the Helpline number quoting Model number and Serial number on the product, or write to Morphy Richards at the address shown.

You may be asked to return a copy of proof of purchase.

Subject to the exclusions set out below (see Exclusions) the faulty appliance will then be repaired or replaced and dispatched usually within 7 working days of receipt.

If for any reason this item is replaced during the 2 year guarantee period, the guarantee on the new item will be calculated from original purchase date. Therefore it is vital to retain your original till receipt or invoice to indicate the date of initial purchase.

To qualify for the 2 year guarantee the appliance must have been used according to the manufacturers instructions. For example kettles should have been regularly descaled.

### **EXCLUSIONS**

Morphy Richards shall not be liable to replace or repair the goods under the terms of the guarantee where:

- 1 The fault has been caused or is attributable to accidental use, misuse, negligent use or used contrary to the manufacturers recommendations or where the fault has been caused by power surges or damage caused in transit.
- 2 The appliance has been used on a voltage supply other than that stamped on the products.

- 3 Repairs have been attempted by persons other than our service staff (or authorised dealer).
- 4 Where the appliance has been used for hire purposes or non domestic use.
- 5 Morphy Richards are not liable to carry out any type of servicing work, under the guarantee.
- 6 Plastic filters for all Morphy Richards kettles and coffee makers are not covered by the guarantee.

This guarantee does not confer any rights other than those expressly set out above and does not cover any claims for consequential loss or damage. This guarantee is offered as an additional benefit and does not affect your statutory rights as a consumer.

### **AUSTRALIAN WARRANTY**

This appliance is guaranteed for 2 years against faulty material, components and workmanship.

This warranty is in addition and does not affect your statutory rights.

Proof of purchase must be produced for any warranty benefit.

In the unlikely event of any appliance proving to be faulty, securely pack and return the item to the place of purchase accompanied by the original receipt or invoice.

### **NOT COVERED BY THIS WARRANTY (Australian only)**

- If the appliance has not been used in accordance with the manufacturers' recommendations or instructions.
- If the fault is deemed to be caused by abuse, misuse, neglect, modifications or in proper use and or care  
Eg: Kettles: Excessive build up of scale.  
Toasters: Excessive build up of crumbs or foreign matter etc.
- Connection to incorrect voltage to that stamped on the product
- Unauthorised repairs
- Appliance used other than for domestic purposes.

- Excluding bags, filters, glass, carafes, and cutting blades.
- Freight and insurance costs.

If for any reason this item is replaced during the 2 year guarantee period, the guarantee on the new item will be calculated from original purchase date. Therefore it is vital to retain your original receipt or invoice to indicate the date of original purchase.

Morphy Richards's policy is to continually improve quality design and product quality. The company therefore reserves the right to change any specifications or to carry out modifications as deemed worthy at any time.

The Australian supplier ASKO Appliances reserves the right to repair, modify, exchange or replace the faulty appliance with the same or similar model or product of equivalent value.

## **SERVICE CENTRE ADDENDUM**

### **Locations**

#### **Asko Appliances (Australia)**

##### **Pty Ltd**

Victoria

35 Sunmore Close

Moorabbin 3189

03 8551 2200

#### **New South Wales**

F3/3-9 Birnie Ave

Lidcombe 2141

02 8748 2900

#### **Queensland**

2/112 Fison Ave

Eagle Farm 4009

07 3623 2700

#### **South Australia**

45 Hampton Road

Keswick 5035

08 8292 9500

#### **Western Australia**

15 Walters Drive

Osborne Park 6017

08 9347 0600

---

**AUS** Morphy Richards products are intended for household use only. Morphy Richards has a policy of continuous improvement in product quality and design. The Company, therefore, reserves the right to change the specification of its models at any time.

**morphyrichards**

TT4472XMAUS Rev 2 10/07

[www.morphyrichards.com](http://www.morphyrichards.com)