morphyrichards



2 slice hardware toaster
Please read and keep these instructions



www.morphyrichards.com

Getting the best from your new appliance...

- **Safety first**
Do not touch metal top of the appliance during or after use as it gets very hot.
- **Empty crumb tray regularly**
To clean away any crumbs that accumulate after use.
- **In order to achieve uniform browning**
Wait a minimum of 30 seconds between each toasting, so that the control can automatically reset.

Important safety instructions

The use of any electrical appliance requires the following common sense safety rules.

Primarily there is danger of injury or death and secondly the danger of damage to the appliance. These are indicated in the text by the following two conventions:

WARNING: Danger to the person!

IMPORTANT: Damage to the appliance! In addition we offer the following safety advice.

Location

- Always locate your appliance away from the edge of the worktop.
- Ensure that the appliance is used on a firm, flat, heat resistant surface.
- Ensure that sufficient space is left above and around all sides of your appliance to allow air to circulate.
- IMPORTANT: Do not use too close to curtains, draperies, walls, cupboards and other flammable materials.
- **WARNING: Do not use underneath cupboards.**
- Do not use outdoors.

Mains lead

- The mains lead should reach from the socket to the appliance without straining the connections. Reduce the length of the excess lead by using the cord storage facility.
- Do not let the mains lead hang over the edge of the worktop where a child could reach it.
- Do not let the lead run across an open space e.g. between a low socket and table.
- Do not let the lead run across a cooker or hot area which might damage the cable.

Personal safety

- Do watch your appliance during use.
- **WARNING: Do not immerse cord, plug or appliance in water or other liquid.**
- **WARNING: Do not touch the top of the appliance or other hot parts during or after use, use handles or knobs.**
- **WARNING: Do not insert oversize foods, metal, foil packages or utensils into the appliance.**
- **WARNING: Do not attempt to dislodge food when the appliance is plugged in and never insert cooking utensils into the slots.**
- IMPORTANT: Do not place bread or other items on top of the slots as this may damage the appliance and creates a fire hazard.

Children

- Never allow a child to operate this appliance.
- This appliance is not intended to be used by young children or infirm persons unless they have been adequately supervised by a responsible person to ensure they can use the appliance safely.
- Young children should be supervised to ensure that they do not play with the appliance.

- Children are vulnerable in the kitchen particularly when unsupervised and if appliances are being used or cooking is being carried out.
- Teach children to be aware of dangers in the kitchen, warn them of the dangers of reaching up to areas where they cannot see properly or should not be reaching.

Other safety considerations

- Do not operate with a damaged cord or plug or after the appliance malfunctions or has been damaged in any manner.
- Do not attempt repairs - the appliance contains no user-serviceable parts. Call our helpline for advice.
- Do not use accessories not recommended by the manufacturer.
- Do not place on or near a hot gas electric burner or in a heated oven.
- Only use for intended purpose.
- Unplug from outlet when not in use and when cleaning.
- Do not move the appliance whilst hot.

Electrical requirements

Check that the voltage on the rating plate of your appliance corresponds with your house electricity supply which must be A.C. (Alternating current).

If the socket outlets in your home are not suitable for the plug supplied with this appliance the plug should be removed and the appropriate one fitted.

WARNING : The plug removed from the mains lead, if severed, must be destroyed as a plug with a bared flexible cord is hazardous if engaged into a live socket outlet.

Where used, should the fuse in the 13 amp plug require changing a 13 amp BS1362 fuse must be fitted.

WARNING: This appliance must be earthed.

Features A

- 1 Bread slots
- 2 Bread carriage levers with high lift feature
- 3 Frozen button ❄️
- 4 Reheat button 🔥
- 5 Cancel button ⏹️
- 6 Electronic variable browning control
- 7 Removable crumb tray at rear
- 8 Cord storage

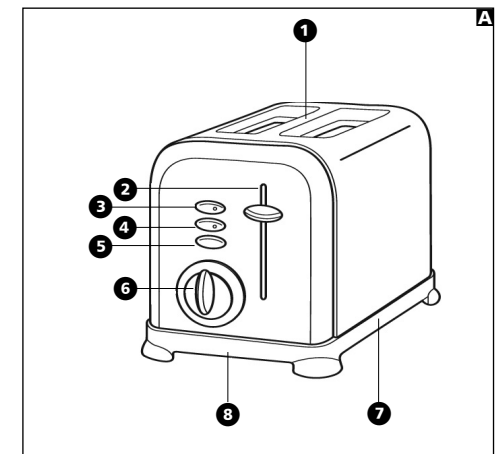

Before first use

Before using the appliance for the first time operate the toaster without bread in a ventilated room.

- The bread carriage levers **2** will not stay down unless the toaster is connected to the mains supply.
- As with all new electric heating elements, your toaster emits a 'new' smell when it is first switched on which is quite normal.

Toasting

- 1** Select the desired level of browning on the browning control **6** marked 1 to 9. The setting required will vary according to the moisture content and thickness of the bread.
 - 2** After selecting the desired level, place your bread in the slots **1** and depress the bread carriage lever downwards until it locks.
 - 3** After the set time has been reached the bread will pop up automatically ready for removal from the slots. The bread carriage lever will have returned to its upper position and the heating element will have switched off.
- If the bread in your toaster becomes jammed disconnect your toaster at the socket, allow it to cool, then remove the bread.
 - When not in use, remove the plug from the mains socket.
 - Allow the toaster to cool fully before putting away.

WARNING: Do not wrap the cable around the main body of the appliance during or after use.

Using the frozen button

To toast frozen bread do not adjust the browning control from your normal preferred setting, place the bread normally in the bread slots, then depress the relevant bread carriage lever and press the frozen button **3**.

Using the re-heat button

If your toast has popped up and gone cold, the toaster offers a re-heat facility. To use, depress the relevant bread carriage lever and press the re-heat button **4** immediately. The button will illuminate and the toaster will operate for a short period re-heating the bread.

Using the cancel button

If you wish to interrupt the toasting process, press the cancel button **5**.

Hints & tips for perfect toasting

- For best results ensure the bread slices are of even thickness, freshness and size.
- Stale bread toasts more rapidly than fresh bread. Therefore, the browning control should be set at a lower setting than usual.
- Thin bread toasts quicker than thick.
- In order to achieve uniform browning, we recommend you wait a minimum of 30 seconds between each toasting so that the control automatically resets.
- If toasting one slice only, you may need to adjust the browning control to a slightly lower setting.
- You may notice a slight variation in toast colour on one side of a single slice.
- All sorts of bread can be used as well as teacakes, small rolls etc. Slices should not however be so thick as to cause burning or jamming within the bread slots.
- When toasting more than one slice it is recommended they are of equal size and freshness.

Crumb trays **B**

WARNING: Crumbs will accumulate in the crumb tray and could catch fire if not emptied periodically.

When the toaster has cooled down completely, tap the sides of the case lightly to dislodge any crumbs lodged in the toasting chamber and remove the crumb trays **7**. Empty the tray and replace it.

Never operate the toaster without the crumb trays fitted.

Cleaning and maintenance

- 1** After use and before cleaning, remove the plug from the wall socket and wait for the toaster to cool.
 - 2** Wipe the outside of the toaster with a damp cloth only and dry with another cloth or tissue.
- NEVER use metal polish or coarse scouring agents and never immerse your toaster in any sort of liquid.
 - NEVER use any pointed or sharp articles for cleaning the inside, otherwise the heating element will be damaged.
 - NEVER use a brush or push your fingers or metal objects down the slots.

Helpline

If you have any difficulty with your appliance, do not hesitate to call us.

We are more likely to be able to help than the store from where you bought it.

Please have the following information ready to enable our staff to deal with your query quickly.

- Name of the product
- Model number as shown on the underside of the appliance.

Your two-year guarantee

It is important to retain the retailers receipt as proof of purchase. Staple your receipt to this back cover for future reference.

Please quote the following information if the product develops a fault. These numbers can be found on the base of the product.

Model no. Serial no.

All Morphy Richards products are individually tested before leaving the factory. In the unlikely event of any appliance proving to be faulty within 28 days of purchase it should be returned to the place of purchase for it to be replaced.

If the fault develops after 28 days and within 24 months of original purchase, you should contact Morphy Richards quoting Model number and Serial number on the product, or write to Morphy Richards at the address shown.

You may be asked to return a copy of proof of purchase.

Subject to the exclusions set out below (1-6) the faulty appliance will then be repaired or replaced and dispatched usually within 7 working days of receipt.

If for any reason this item is replaced during the 2-year guarantee period, the guarantee on the new item will be calculated from original purchase date. Therefore it is vital to retain your original till receipt or invoice to indicate the date of initial purchase.

To qualify for the 2-year guarantee the appliance must have been used according to the manufacturers instructions. For example, appliances must have been descaled and filters must have been kept clean as instructed.

Morphy Richards shall not be liable to replace or repair the goods under the terms of the guarantee where:

- 1** The fault has been caused or is attributable to accidental use, misuse, negligent use or used contrary to the manufacturers recommendations or where the fault has been caused by power surges or damage caused in transit.
- 2** The appliance has been used on a voltage supply other than that stamped on the products.
- 3** Repairs have been attempted by persons other than our service staff (or authorised dealer).

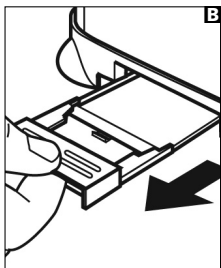

- 4 Where the appliance has been used for hire purposes or non domestic use.
- 5 Morphy Richards are not liable to carry out any type of servicing work, under the guarantee.
- 6 The guarantee excludes consumables such as bags, filters and glass carafes.

This guarantee does not confer any rights other than those expressly set out above and does not cover any claims for consequential loss or damage. This guarantee is offered as an additional benefit and does not affect your statutory rights as a consumer.

AUSTRALIAN WARRANTY

This appliance is guaranteed for 2 years against faulty material, components and workmanship.

This warranty is in addition and does not affect your statutory rights.

Proof of purchase must be produced for any warranty benefit.

In the unlikely event of any appliance proving to be faulty, securely pack and return the item to the place of purchase accompanied by the original receipt or invoice.

NOT COVERED BY THIS WARRANTY *(Australian only)*

- If the appliance has not been used in accordance with the manufacturers' recommendations or Instructions.
- If the fault is deemed to be caused by abuse, misuse, neglect, modifications or in proper use and or care
Eg: Kettles: Excessive build up of scale.
Toasters: Excessive build up of crumbs or foreign matter etc.
- Connection to incorrect voltage to that stamped on the product
- Unauthorised repairs
- Appliance used other than for domestic purposes.

- Excluding bags, filters, glass, carafes, and cutting blades.
- Freight and insurance costs.

If for any reason this item is replaced during the 2 year guarantee period, the guarantee on the new item will be calculated from original purchase date. Therefore it is vital to retain your original receipt or invoice to indicate the date of original purchase.

Morphy Richards's policy is to continually improve quality design and product quality. The company therefore reserves the right to change any specifications or to carry out modifications as deemed worthy at any time.

The Australian supplier ASKO Appliances reserves the right to repair, modify, exchange or replace the faulty appliance with the same or similar model or product of equivalent value.

SERVICE CENTRE ADDENDUM

Locations

**Asko Appliances (Australia)
Pty Ltd**
Victoria
35 Sunmore Close
Moorabbin 3189
03 8551 2200

New South Wales
F3/3-9 Birnie Ave
Lidcombe 2141
02 8748 2900

Queensland
2/112 Fison Ave
Eagle Farm 4009
07 3623 2700

South Australia
45 Hampton Road
Keswick 5035
08 8292 9500

Western Australia
15 Walters Drive
Osborne Park 6017
08 9347 0600

AUS Morphy Richards products are intended for household use only.
Morphy Richards has a policy of continuous improvement in product quality and design.
The Company, therefore, reserves the right to change the specification of its models at any time.

morphy richards[®]

TT44063MAUS Rev 2 10/07

www.morphyrichards.com